

FIR 35, 75 and 100

- The FIR series is purposely designed and robustly built to withstand the rugged environment in the welding industry.
- This unit is part of a growing line and especially in wind-tower production.
- FIR has four independently adjusted rollers to align the can with each other and two cross rollers to lift up the tower section.
- The FIR is mounted on one main frame.

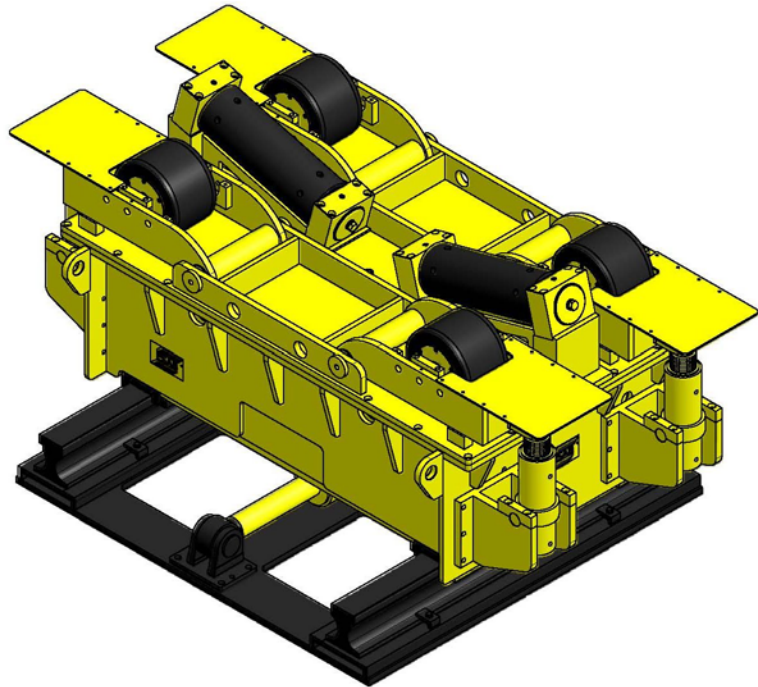

Applications

- **Vessels**
- **Wind Tower**
- **Pipe Mill**



Technical data FIR 35 / 75 / 100

Max load, tons	35 / 75 / 100
Min diameter, mm	610 mm at 90° included angle
Max diameter, mm	6435 mm at 30° included angle
Tire type	Steel
Roller speed	Freely rotation
Control voltage	24V DC
Supply voltage	400V-3P-50Hz 460V-3P-60Hz
Control	Pendant via push button



Ordering Information

Please contact nearest ESAB sales office for more information



www.esab.com



22/12/2008